

The AD-25/WB-3512 is a wideband VHF/UHF dipole ("center-fed") antenna, primarily intended for use with manpack portable radio units in VHF/UHF frequency range from 30 to 512 MHz. Electrically the antenna is optimized for all exploitation conditions (portable radio unit on operator body, hand, ground, etc.) so it is not necessary to additionally tune the antenna. The antenna is composed of six basic elements (from the bottom up): Current-choke unit, flexible goose-neck, matching unit, flexible goose-neck, coil unit and tape radiator. Current-choke unit allows antenna to be independent of the portable radio unit and so forms a correct dipole shape. Flexible goose-neck allows bending the antenna to be always in vertical position. Matching unit with a special built-in passive transformer tuning network is enclosed in a plastic housing. Tape radiator is made of flexible tapes covered with a plastic tube ensuring high flexibility and roughness. Antenna connector is TNC male.

ELECTRICAL SPECIFICATIONS	
Frequency range	30 - 512 MHz
Impedance	50 ohm
VHF VSWR	VHF (30 - 225 MHz) < 3.5
UHF VSWR	UHF (225 - 512 MHz) < 3
VHF Gain	VHF (30 - 225 MHz) -20 ... -2 dBi
UHF Gain	UHF (225 - 512 MHz) -3 ... +3 dBi
Polarization	Vertical
Maximum power	20 W CW
Connector	TNC male
MECHANICAL SPECIFICATIONS	
Design	VHF/UHF Dipole Antenna
Height	1300 mm
Weight	500 g
Diameter	22 mm
Temperature range - in use	-50 ... +55 °C
Temperature range - in stock	-55 ... +75 °C
Color	Black
ENVIRONMENTAL SPECIFICATIONS (per MIL-STD-810G)	
High Operating Temperature	+85 °C Method 501.5 Proc. II
Low Operating Temperature	-40 °C Method 502.5 Proc. II
High Temperature Storage	+85 °C Method 501.5 Proc. I
Low Temperature Storage	-50 °C Method 502.5 Proc. I
Humidity	Method 507.5 Proc. II
Salt Fog	Method 509.5
Vibration	Method 514.6 Proc. I
Immersion	Method 512.5 Proc. I
Rain	Method 506.4 Proc. II
Sand and Dust	Method 510.5 Proc. I
Solar Radiation	Method 505.5 Proc. I
Fungus	Method 508.5
Altitude	Method 500.5 Proc. I

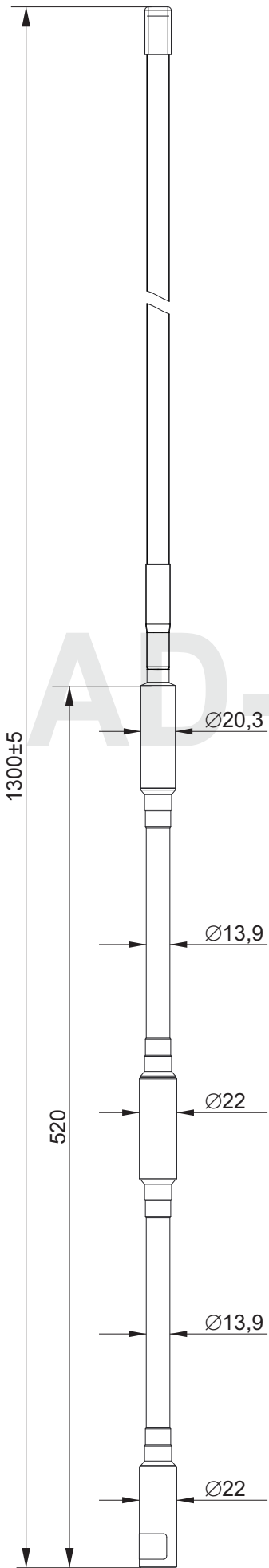



VSWR

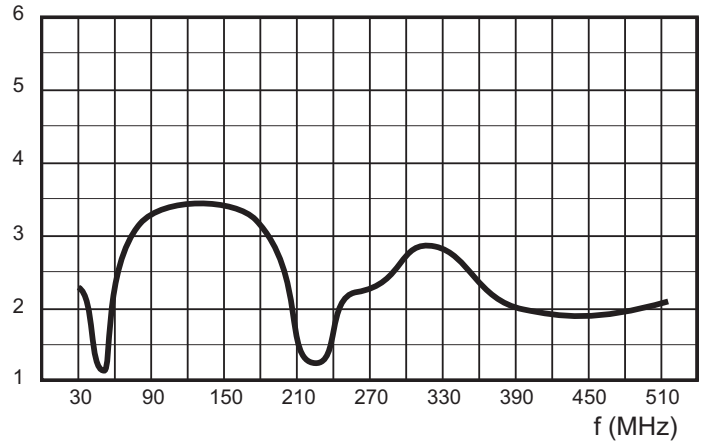

Gain

